

MODELLO MOD.	CHIOCCIOLA SINGOLA PRECARICATA PRELOADED FLANGED SINGLE BALLNUT	TAB.2 TAB. 2	DIN69051/5 DIN69051/5
------------------------	---	------------------------	---------------------------------

Ricircolo interno
Dispositivo di ricircolo in acciaio
Precarico = max. 8% di C dyn
Dimensioni speciali a richiesta
Raschiatori in materiale plastico (standard).
A richiesta in PTFE autolubrificante

Internal recirculation system
Steel-made recirculation device
Preload = max. 8% of C dyn
Special dimensions on request
Standard: Nylon wipers.
On request: Special selflubricating PTFE material

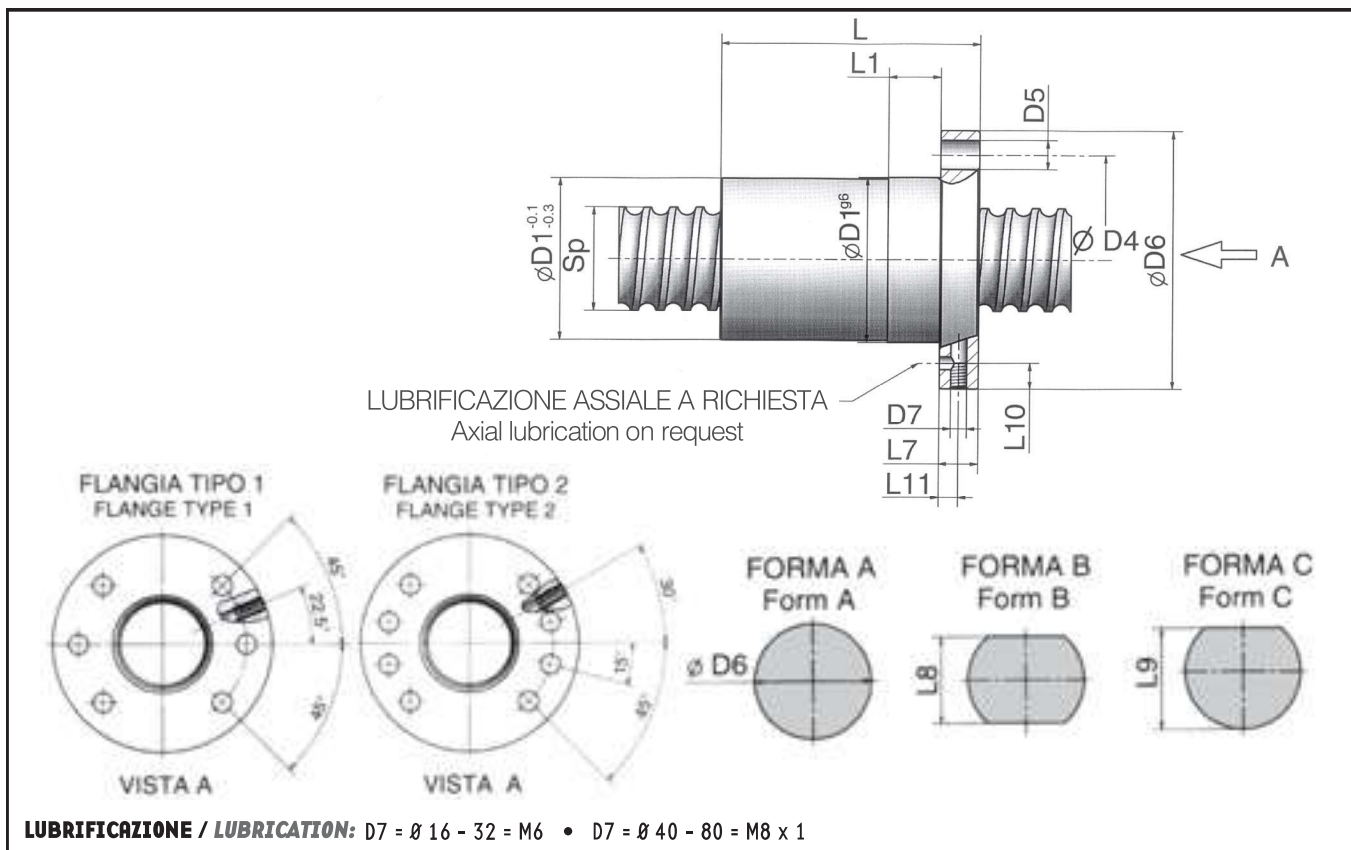

Tipo/ Size		Circuiti/ Effect. turns i	Capacità di carico/ Basic Rate Load		Rigidità/ Stiffness Rb/t KN/um	Dimens.chiocciola / Nut dimensions											Sfera Ball mm	Sp(h6) mm
d0 mm	Ph mm		Cdyn (KN)	Cstat (KN)		L mm	D1g6 mm	D4 mm	D5 mm	D6 mm	D7 mm	L1 mm	L7 mm	L8 mm	L9 mm	L10 mm		
16	4	3	8,05	11,08	1,05	45	28	38	5,5	48	10	10	40	44	8	5	2,38	16
	5	3	8,05	11,08	1,04	45												
20	4	4	11,61	19,14	1,41	52	36	47	6,6	58	10	10	44	51	8	5	2,38	20
	5	4	17,09	25,37	1,80	52												
25	4	3	9,61	16,95	1,08	45	40	51	6,6	62	10	10	48	55	8	5	2,38	24
		4	12,53	23,19	1,43	50												
	3	16,24	24,39	1,38	50													
	4	21,18	33,48	1,82	60													
	3	16,23	24,37	1,38	50													
	4	21,17	33,45	1,82	60													
	2	10,98	15,20	0,92	50													
	3	16,17	24,24	1,37	60													
32	4	4	13,71	29,07	1,47	50	50	65	9	80	10	12	62	71	8	6	2,38	30
		6	19,78	44,78	2,18	60												
		3	17,93	30,95	1,41	50												
	5	4	23,39	42,24	1,86	60												
		6	33,75	65,25	2,76	70												
		3	25,34	39,61	1,90	55												
	6	4	33,05	54,63	2,51	65												
		6	47,68	84,00	3,71	75												
		2	17,17	24,50	1,26	60												
	10	3	25,28	39,48	1,89	70												
		4	32,98	54,45	2,50	80												
		2	17,01	24,80	1,24	80												
20	3	25,04	39,54	1,85	100													

Tipo/ Size		Circuiti/ Effect. turns i	Capacità di carico/ Basic Rate Load		Rigidità/ Stiffness Rb/t KN/um	Dimens.chiocciola / Nut dimensions											Sfera Ball mm	Sp(h ₆) mm								
d0 mm	Ph mm		Cdyn (KN)	Cstat (KN)		L mm	D1g6 mm	D4 mm	D5 mm	D6 mm	D7 mm	L1 mm	L7 mm	L8 mm	L9 mm	L10 mm			L11 mm							
40	5	3	19,79	39,27	1,44	56	63	78	9	93	10	14	70	81,5	7	3,5	38									
		4	25,81	53,63	1,91	62																				
		5	37,24	83,20	2,83	70																				
	6	3	28,13	50,47	1,93	56																				
		4	36,69	69,14	2,55	62																				
		6	52,93	107,17	3,78	70																				
	8	3	44,83	70,27	2,60	68																				
		4	58,47	97,29	3,44	78																				
		6	84,29	149,82	5,09	98																				
	10	3	44,79	70,18	2,56	68																				
		4	58,43	97,18	3,44	88																				
		6	84,29	149,82	5,09	98																				
16	2	30,33	44,32	1,73	68																					
	3	44,65	71,18	2,58	85																					
	4	58,24	96,69	3,42	100																					
20	2	30,24	44,11	1,72	75																					
	3	44,52	70,85	2,57	95																					
	4	58,47	97,29	3,44	110																					
50	5	3	21,72	49,77	1,49	56	75	93	11	110	16	16	85	97,5	8	48										
		4	28,33	68,49	1,97	62																				
		6	40,87	105,51	2,93	70																				
	6	3	30,99	64,21	1,98	56																				
		4	40,42	87,94	2,62	62																				
		6	58,31	136,10	3,85	70																				
	10	3	61,65	102,03	2,63	90																				
		4	80,41	141,71	3,49	100																				
		6	116,01	219,19	5,16	120																				
	16	3	61,52	103,58	2,67	100																				
		4	80,24	141,24	3,47	120																				
		6	116,01	219,19	5,16	140																				
20	3	61,40	103,26	2,62	100																					
	4	80,08	140,81	3,46	135																					
	6	116,01	219,19	5,16	150																					
63	5	3	21,72	49,77	1,54	56	90	108	11	125	10	18	95	110	9	60										
		4	28,33	68,49	2,04	62																				
		6	40,87	105,51	3,03	70																				
	6	3	33,85	80,83	2,03	65																				
		4	44,16	110,35	2,69	70																				
		6	63,70	170,10	3,98	82																				
	10	3	68,35	130,14	2,69	84																				
		4	89,15	177,99	3,56	94																				
		6	128,61	275,60	5,27	120																				
	20	3	94,87	167,01	3,79	130																				
		4	123,74	230,77	5,02	150																				
		6	180,88	340,16	7,59	200																				
80	5	4	34,43	114,84	2,14	70	105	125	13,5	145	10	20	110	127,5	10	80										
		6	49,67	176,78	3,18	80																				
		8	80,30	208,17	3,68	105																				
	10	6	115,84	321,33	5,45	125																				
		8	149,66	433,10	7,20	145																				
		6	140,86	308,81	5,13	160																				
	20	6	203,21	475,57	7,59	200																				
		3	159,37	297,83	3,87	140																				
		4	207,87	406,14	5,13	160																				
	100	10	6	126,3	402	3,80									125		125	145	13,5	165	16	22	130	147,5	11	100
			6	159	468	7,42									125											
			4	154,60	386,68	5,25									190											
20		6	223,04	598,73	7,77	220																				
		4	230,05	510,11	5,25	190																				
		6	331,88	789,85	7,77	220																				
120		6	170,7	562,8	5,79	125																				
		4	248,63	619,48	5,37	180																				
		6	299,88	628,16	7,59	200																				
160		6	150,75	645,17	6,07	170																				
		4	207,87	406,14	5,13	160																				
		6	299,88	628,16	7,59	200																				

- A richiesta:
Sfere in materiale ceramico
Chiocciola in versione rotante
- Classi di precisione 1-3-5-7 secondo norme ISO/TC39/WG7 179
- Elica destrorsa standard
- Carichi secondo DIN 6905/4
- Rigidità chiocciola secondo DIN 69051/6

- On request:
Ceramic balls
Rotating nut
- Accuracy classes 1-3-5-7 according to ISO/TC 39/WG7 179
- R.H. thread as standard
- Load according to DIN 6905/4
- Nut stiffness according to DIN 69051/6